

Construction plans for the Trotter Frame Pack

Created by Barry Turnbull-Burchmore
2007

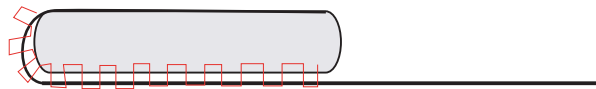

Trotter Frame Pack

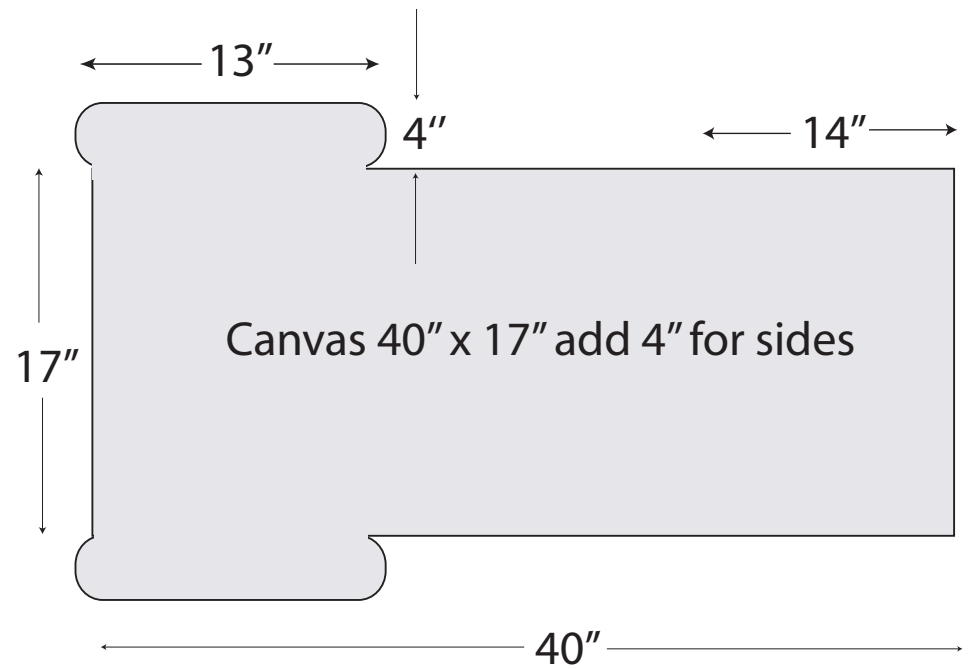
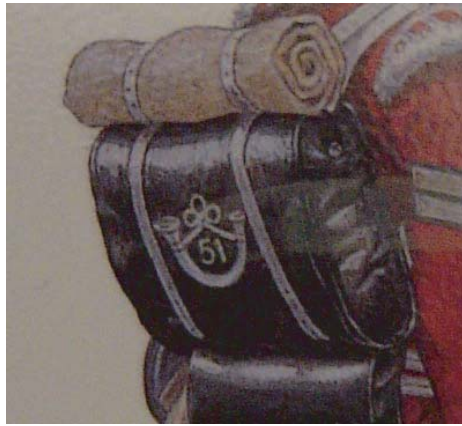

Fold end around the side pieces and stitch in place, ending at the start of the curve.

*All edges should also be over bound by leather.

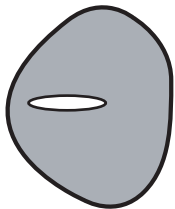

Cut two pieces (approximate shape) and stitch to make two side covers.

*Use either heavy Leather or Canvas.

*Stitch a Button hole in each.

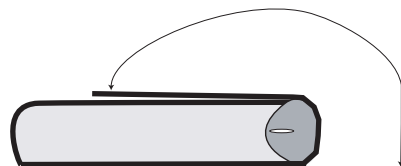
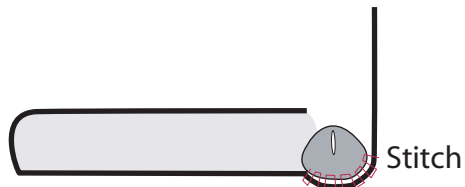
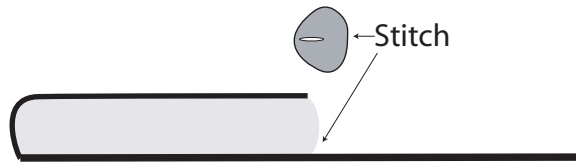

Stitching

Trotter Frame Pack - Inner pocket

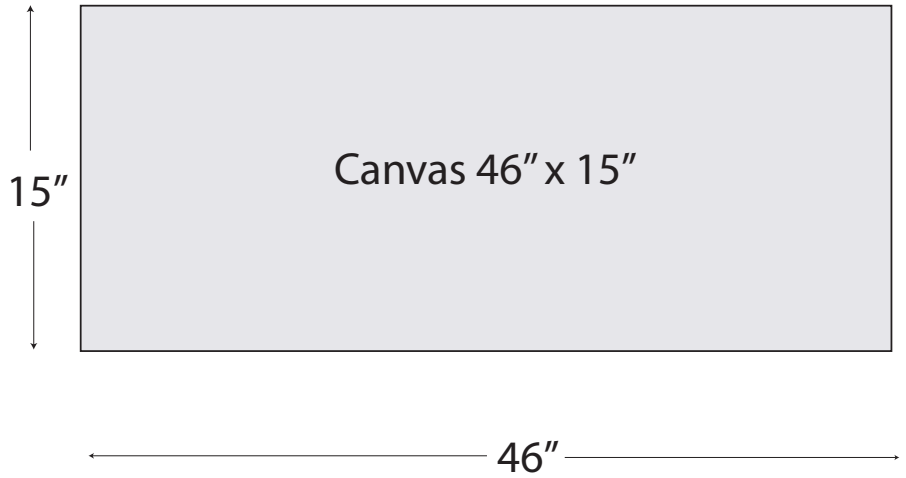

Cut a slot - Approx 12" long and stitch a binding around the opening.
Stitch ties along both sides of the opening.

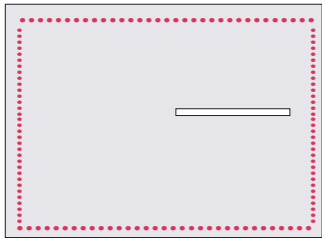

Fold in half and stitch together.



Stitch into place inside the pack

Trotter Frame Pack - Strapping



Pack requires-
2 x Buttons
5 x Buckles and straps
1 x optional inside Buckle and strap

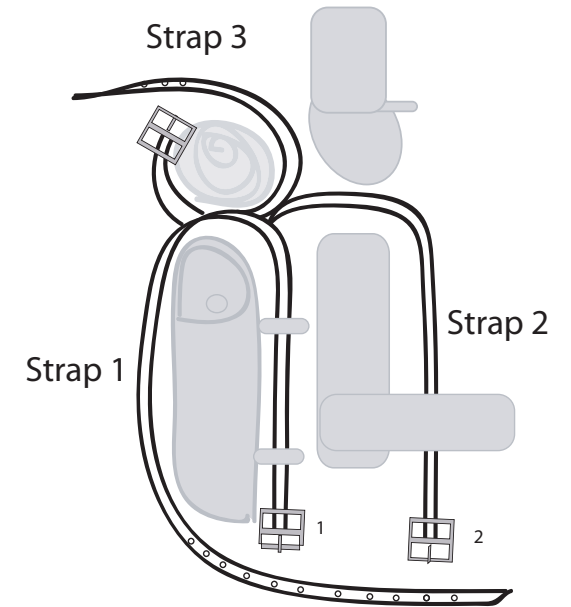

Strap 1, passes through two loops on the back of the pack so that the buckle ends face down. the other end goes over and surrounds the pack and passes through buckle 1, and then through buckle 2.

Strap 2, goes over the shoulder and links to strap 1, the buckle end faces down.

Strap 3, straps the Bedroll or Greatcoat.